

20 19 18 17 16 15 14 13 12 11 10 9 8 7 6 5 4 3 2 1

NOTES:

1. MATERIAL:
 - 1) 70/30 BRASS, PER ES-124C-6.
 - 2) PHOS. BRONZE, PER ES-124E-5.
2. FINISH: SEE LEGEND.
3. THIS PART CONFORMS TO PRODUCT SPEC. 7879.
4. CRIMP FOR 24-30 AWG. WIRE WITH .060/(1.52) MAX. INSULATION DIA.
5. THIS TERMINAL TO BE USED IN 7880 HOUSING.
6. DIMENSIONS GIVEN ACROSS CENTERLINES ARE SYMMETRICAL ABOUT THOSE CENTERLINES WITHIN HALF THE TOTAL TOLERANCE.
7. CRIMP WILL ACCEPT 22 AWG. WIRE WITH .062/(1.57) MAX. INSULATION DIA.

LEGEND:

7879-*(***)*

MATERIAL
 (.20^{+0.000} / .020^{-0.008}) / .008^{+0.0000} / .0008^{-0.0008} THICK

PLATING

(102) OVERALL TIN: .000200/(0.00508) MIN. OVER .000100/(0.00254) MIN. COPPER.
 *(P909) OVERALL HOT TN DP: .000100/(0.00254) MIN.
 (P154) OVERALL TIN: .000100/(0.00254) MIN. OVERALL NICKEL UNDERPLATE: .000050/(0.00127) MIN.
 (208) SELECT GOLD: .000015/(0.00038) MIN.
 *SELECT TIN: .000100/(0.00254) MIN.
 OVERALL NICKEL UNDERPLATE: .000050/(0.00127) MIN.
 (228) SELECT GOLD: .000030/(0.00076) MIN.
 *SELECT TIN: .000100/(0.00254) MIN.
 OVERALL NICKEL UNDERPLATE: .000050/(0.00127) MIN.

*THE PRIMARY SHIPPING CARTON WILL BE LABELED 'COMPLIANT TO RoHS DIRECTIVE 2002/95/EC AND ELV ANNEX II OF DIRECTIVE 2000/53/EC.' CARTONS WITHOUT THIS LABEL MAY CONTAIN PRODUCT WITH TIN-LEAD PLATING.

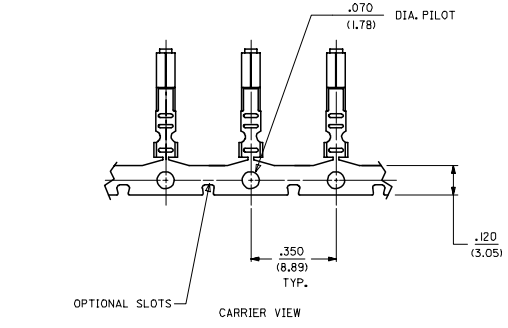
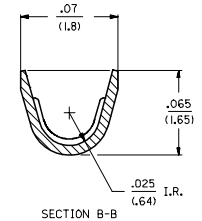
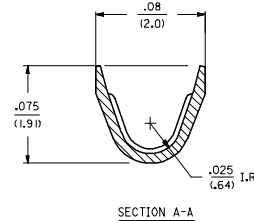
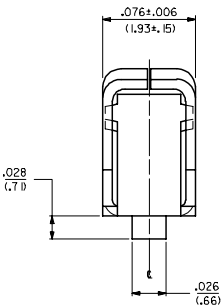
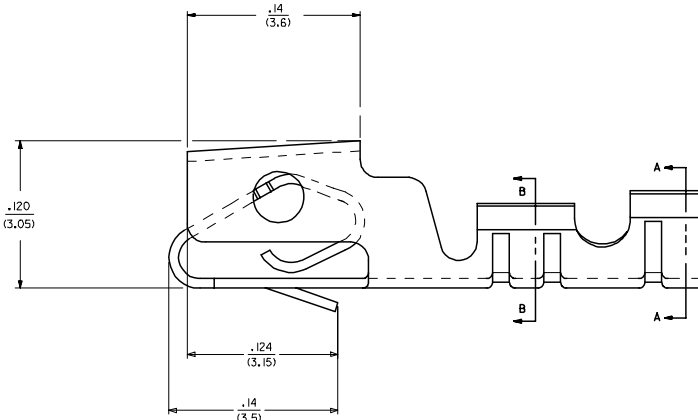
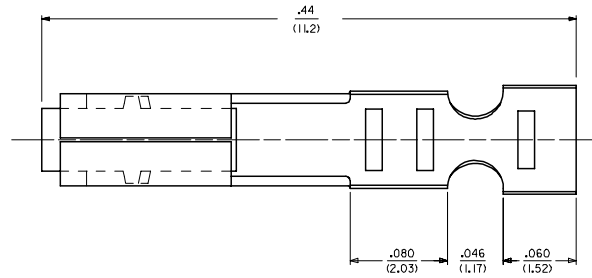

ADD EDP NO'S DEC NO: UCP2006-1006 2006/07/01 DURWALAHAG 2006/07/23 CHIKADDER 2006/07/23 APPR:ESMTJH ZZ	QUALITY SYMBOLS ▽=0 ▽=0	GENERAL TOLERANCES (UNLESS SPECIFIED)		DIMENSION STYLE IN/MM		SCALE ---	DESIGN UNITS INCH	THIRD ANGLE PROJECTION	
		4 PLACES ± --- ± ---	3 PLACES ± --- ± .010	DRAWN BY GUZIK	DATE 12/22/88	TITLE (2.54)/.100 KK, CRIMP TYPE SHROUDED TERMINAL			
		2 PLACES ± 0.25 ± .014	1 PLACE ± 0.36 ± ---	CHECKED BY PATEL	DATE 12/22/88	APPROVED BY LENZ			
		ANGULAR ±1/2°		MATERIAL NO. SEE CHART		DOCUMENT NO. SD-7879		SHEET NO. 1 OF 2	
DRAFT WHERE APPLICABLE MUST REMAIN WITHIN DIMENSIONS				THIS DRAWING CONTAINS INFORMATION THAT IS PROPRIETARY TO MOLEX INCORPORATED AND SHOULD NOT BE USED WITHOUT WRITTEN PERMISSION					

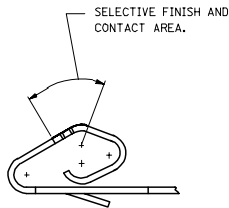

7879-1(***)*			7879-2(***)*		
PART NO.	ENG. NO		PART NO.	ENG. NO	
S 08-55-0128	7879-1P909I	PER ES-7879	50-29-1744	7879-2IP228I	PER ES-7879
S 08-55-0127	7879-1P909L	PER ES-7879	50-29-1745	7879-2IP228L	PER ES-7879
08-55-0124	7879-1P208	PER ES-7879		7879-2IP102I	PER ES-7879
				7879-2IP102L	PER ES-7879
08-55-0129	7879-1P208L	PER ES-7879			
08-50-0004	7879-1P102I	PER ES-7879			
08-50-0005	7879-1P102L	PER ES-7879			
50-29-1900	7879-1P154I	PER ES-7879			

COLUMN NO. 1	CONT. IN COLUMN NO.	SHEET NO.	COLUMN NO. 2	CONT. IN COLUMN NO.	SHEET NO.	COLUMN NO. 3	CONT. IN COLUMN NO.	SHEET NO.
--------------	---------------------	-----------	--------------	---------------------	-----------	--------------	---------------------	-----------

ADD EDP NO'S REC NO: UCP2006-1006 2006/09/01 JORWNAELHAG 2006/09/29 CHKCADDER 2006/09/29 APPROF:SMITH 2006/09/29 ZZ	QUALITY SYMBOLS 	GENERAL TOLERANCES (UNLESS SPECIFIED)		DIMENSION STYLE IN/MM		SCALE ---	DESIGN UNITS INCH	<input checked="" type="checkbox"/> THIRD ANGLE PROJECTION
		4 PLACES ± --- ± --- 3 PLACES ± --- ± --- 2 PLACES ± --- ± --- 1 PLACE ± --- ± --- ANGULAR ±1/2°	mm INCH	DRAWN BY GUZIK DATE 12/22/88	CHECKED BY PATEL DATE 12/22/88	TITLE (2.54)/.100 KK, CRIMP TYPE SHROUDED TERMINAL		
DRAFT WHERE APPLICABLE MUST REMAIN WITHIN DIMENSIONS		SEE CHART		MATERIAL NO. LENZ DATE 12/22/88		MOLEX INCORPORATED DOCUMENT NO. SD-7879		